

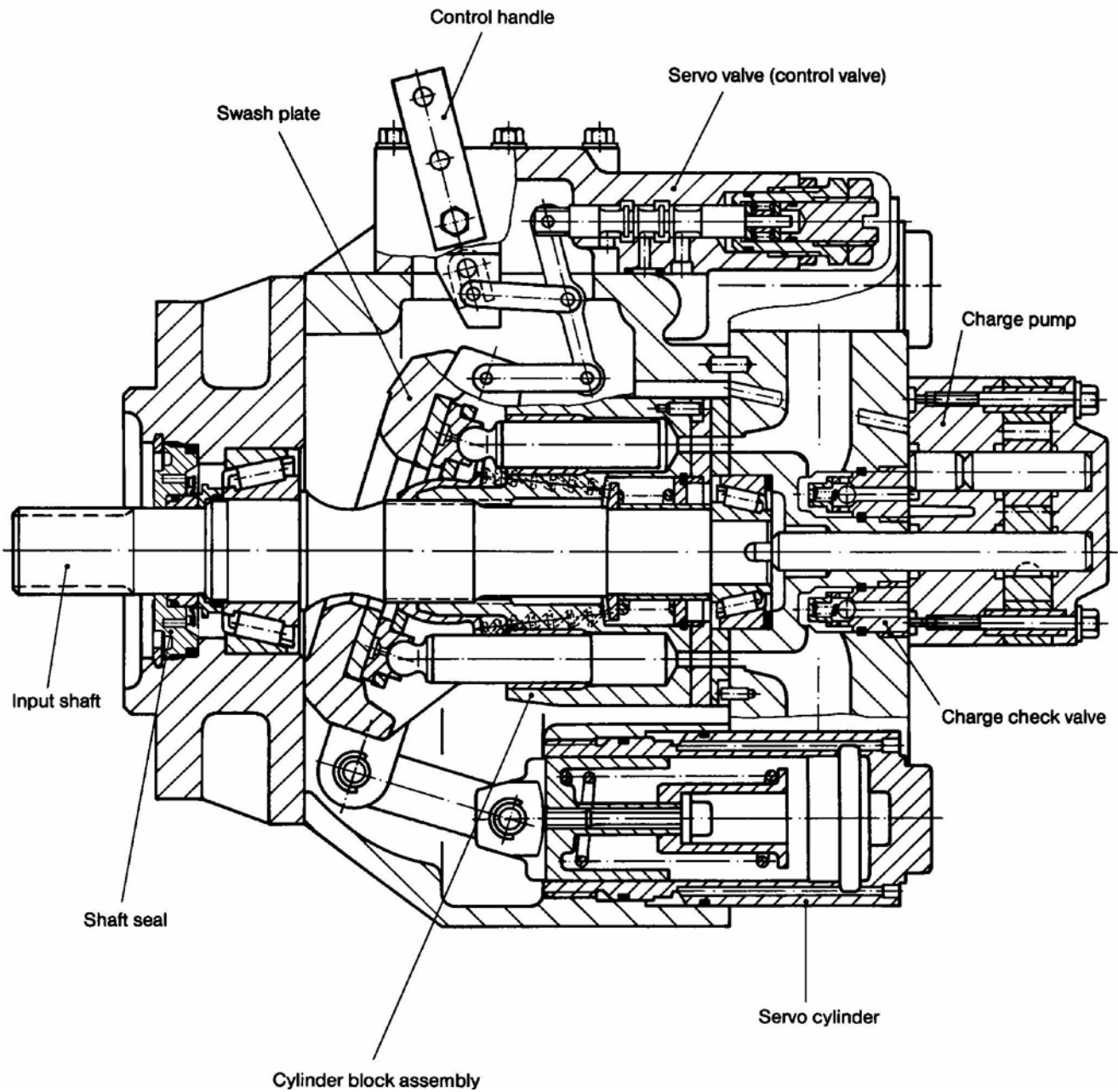

**Axial  
Piston Pumps  
SHPV**

SECTIONAL VIEW



## SYSTEM CIRCUIT

### PUMP AND MOTOR CIRCUIT

- working loop (high pressure)
- working loop (low pressure)
- control fluid
- suction line
- case drain fluid

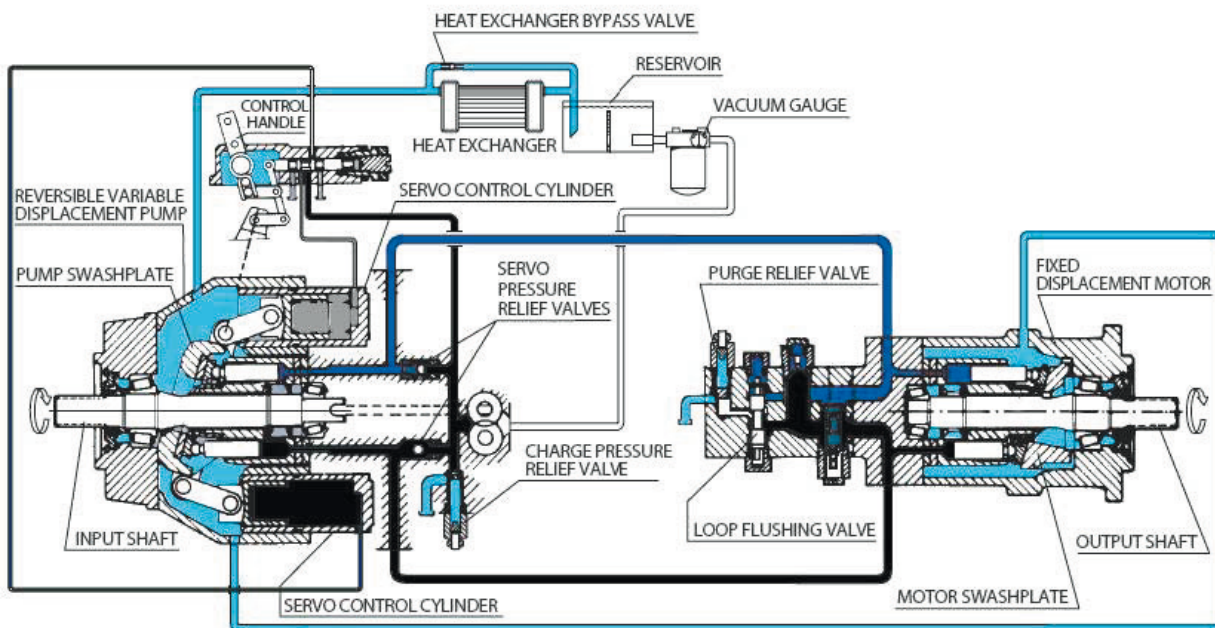

Above figure shows schematically the function of a hydrostatic transmission using an axial piston variable displacement pump and a fixed displacement motor.

### PUMP CIRCUIT SCHEMATIC

Designation:

- 1 = Variable displacement pump
- 2 = Charge pump
- 3 = Servo control valve
- 4 = Charge check valve
- 5 = Charge relief valve
- 6 = Filter
- 7 = Heat exchanger

Ports:

- A, B = Main pressure ports (working loop)
- S = Suction port - charge pump
- L1, L2 = Drain ports
- M = Gauge port - charge pressure

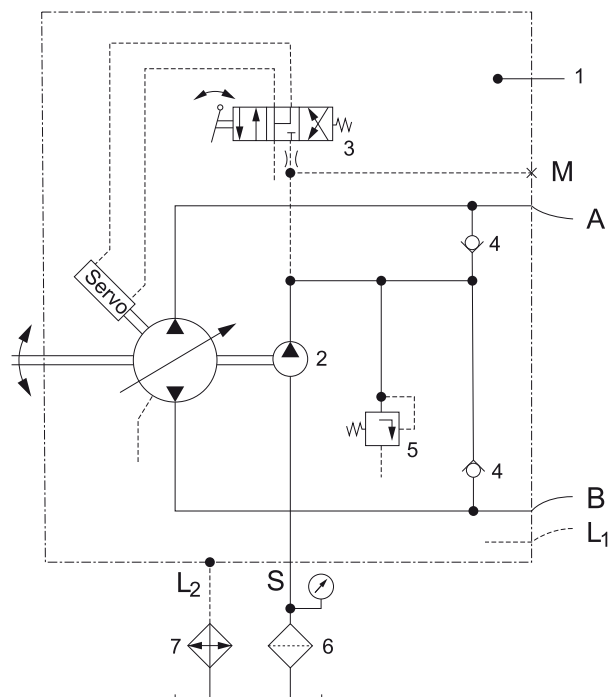

**TECHNICAL SPECIFICATION**
**HYDRAULIC PARAMETERS**

		Frame size							
		20	21	22	23	24	25	26	27
Maximum displacement per revolution of the variable displacement pump	cm <sup>3</sup>	33,3	51,6	69,8	89,0	118,7	165,8	227,3	333,7
	[in <sup>3</sup> ]	[2,03]	[3,15]	[4,26]	[5,43]	[7,24]	[10,12]	[13,87]	[20,36]
Maximum flow	cm <sup>3</sup>	119,54	159,96	196,14	230,51	278,94	348,18	429,59	557,28
	min <sup>-1</sup>								
Displacement per revolution of the charge pump	cm <sup>3</sup>	12,30		18,03		18,85		32,80	65,50
	[in <sup>3</sup> ]	[0,75]		[1,10]		[1,15]		[2,00]	[4,00]
Maximum pressure	bar	420							
	[psi]	[6092]							
Maximum pressure of control	bar	35							
	[psi]	[508]							
Maximum pressure in case	bar	2,5 continuous — 5,0 intermittent							
	[psi]	[36,3 continuous — 72,5 intermittent]							
Maximum speed	min <sup>-1</sup>	3590	3100	2810	2590	2350	2100	1890	1670
Minimum speed	min <sup>-1</sup>	500							
Nominal speed	min <sup>-1</sup>	1500							
Kinematic viscosity range of working fluid:									
	• starting	min <sup>2</sup> s <sup>-1</sup> 1000							
	• operating	min <sup>2</sup> s <sup>-1</sup> 12-600							
	• optimum	min <sup>2</sup> s <sup>-1</sup> 25-35							
Kind of working fluid		mineral oil							
Operating temperature	°C	-40 to +50							
Maximum temperature of working fluid	°C	80							
Purity of working fluid	µm	10							
Direction of shaft rotation		clockwise or counterclockwise							
Maximum swash plate angle	°	± 18							
Weight	kg	45	55	63	78	124	164	212	270
	[lb]	[99]	[121]	[139]	[172]	[273]	[362]	[467]	[595]

## TECHNICAL SPECIFICATION

### DETERMINATION OF NOMINAL PUMP SIZE

Unit: Metric system:

Pump output flow  $Q = \frac{V_g \cdot n_g \cdot \eta_v}{1000}$  l/min

Input torque  $M = \frac{V_g \cdot \Delta p}{20 \cdot \pi \cdot \eta_m}$  Nm

Input power  $P = \frac{V_g \cdot n \cdot \Delta p}{600\,000 \cdot \eta_t}$  kW

Inch system:

Pump output flow  $Q = \frac{V_g \cdot n_g \cdot \eta_v}{231}$  [gpm]

Input torque  $M = \frac{V_g \cdot \Delta p}{2 \cdot \pi \cdot \eta_m}$  [lbf·in]

Input power  $P = \frac{V_g \cdot n \cdot \Delta p}{396\,000 \cdot \eta_t}$  [hp]

Efficiency characteristic curves available on request.

- $V_g$  = Pump displacement per revolution cm<sup>3</sup> [in<sup>3</sup>]
- $n$  = Pump speed min<sup>-1</sup> (rpm)
- $\Delta p$  = Hydraulic pressure differential bar [psi]
- $\eta_v$  = Pump volumetric efficiency
- $\eta_m$  = Pump mechanical efficiency
- $\eta_t$  = Pump total efficiency

### TECHNICAL PARAMETERS

#### Design

Axial piston pump of swash plate design, with variable displacement.

#### Type of mounting

SAE four bolt flanges.

#### Pipe connections

Main pressure ports: SAE split flange  
 Remaining ports: SAE O-ring boss

#### Direction of rotation

Clockwise or counterclockwise (viewing from the input shaft).

#### Installation position

Optional; pump housing must be always filled with hydraulic fluid.

#### External drain fluid loss

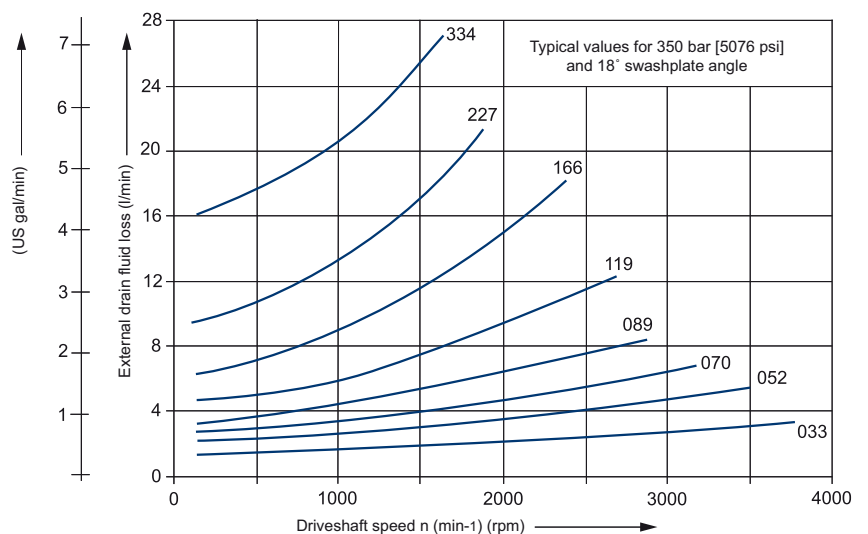

DRAWINGS

FRAME SIZE 20, 21, 22 AND 23

\* Shaft spline data: spline shaft with involute spline, according to SAE handbook, 1963, class 1, fillet root side fit.

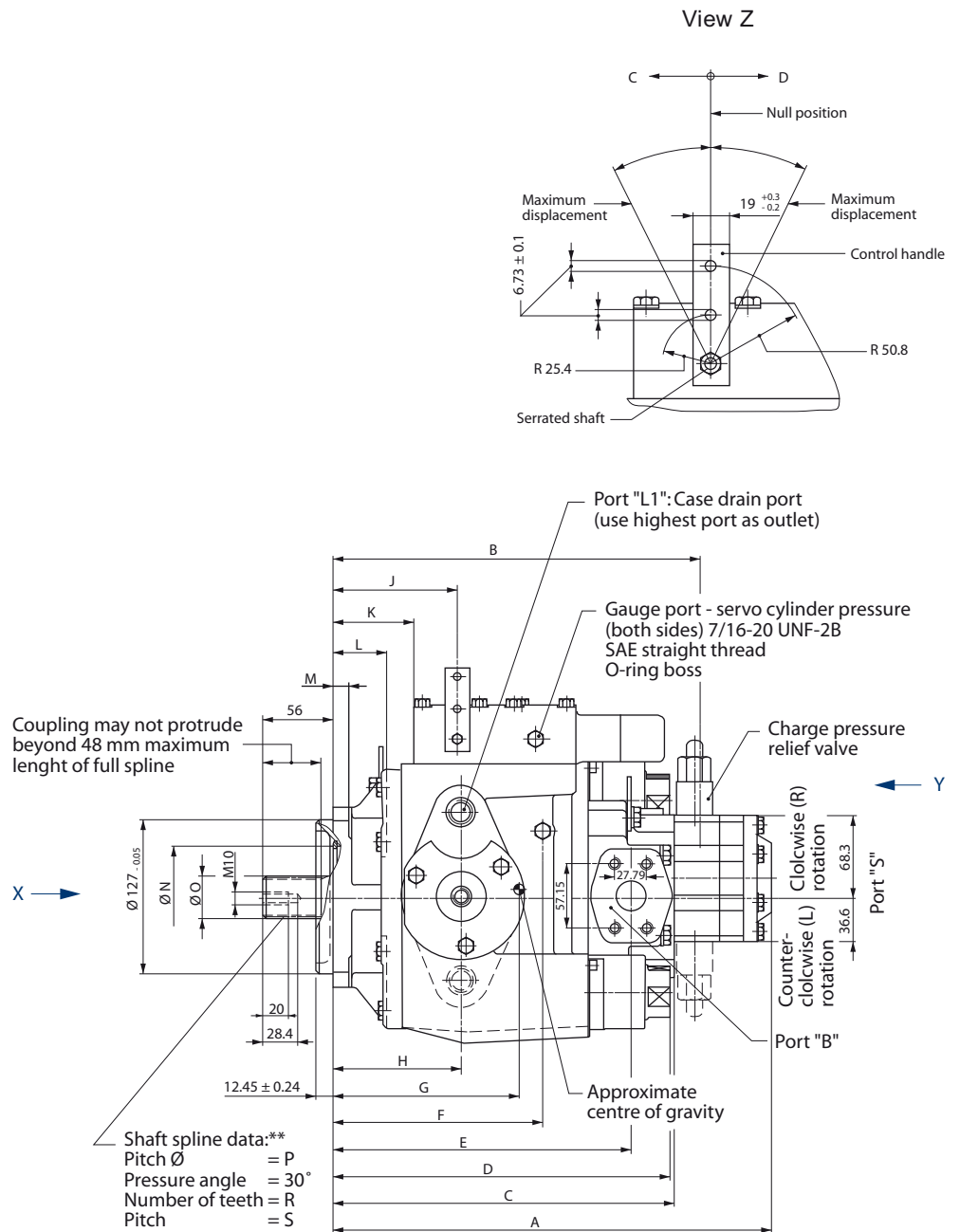

DRAWINGS

FRAME SIZE 20, 21, 22 AND 23

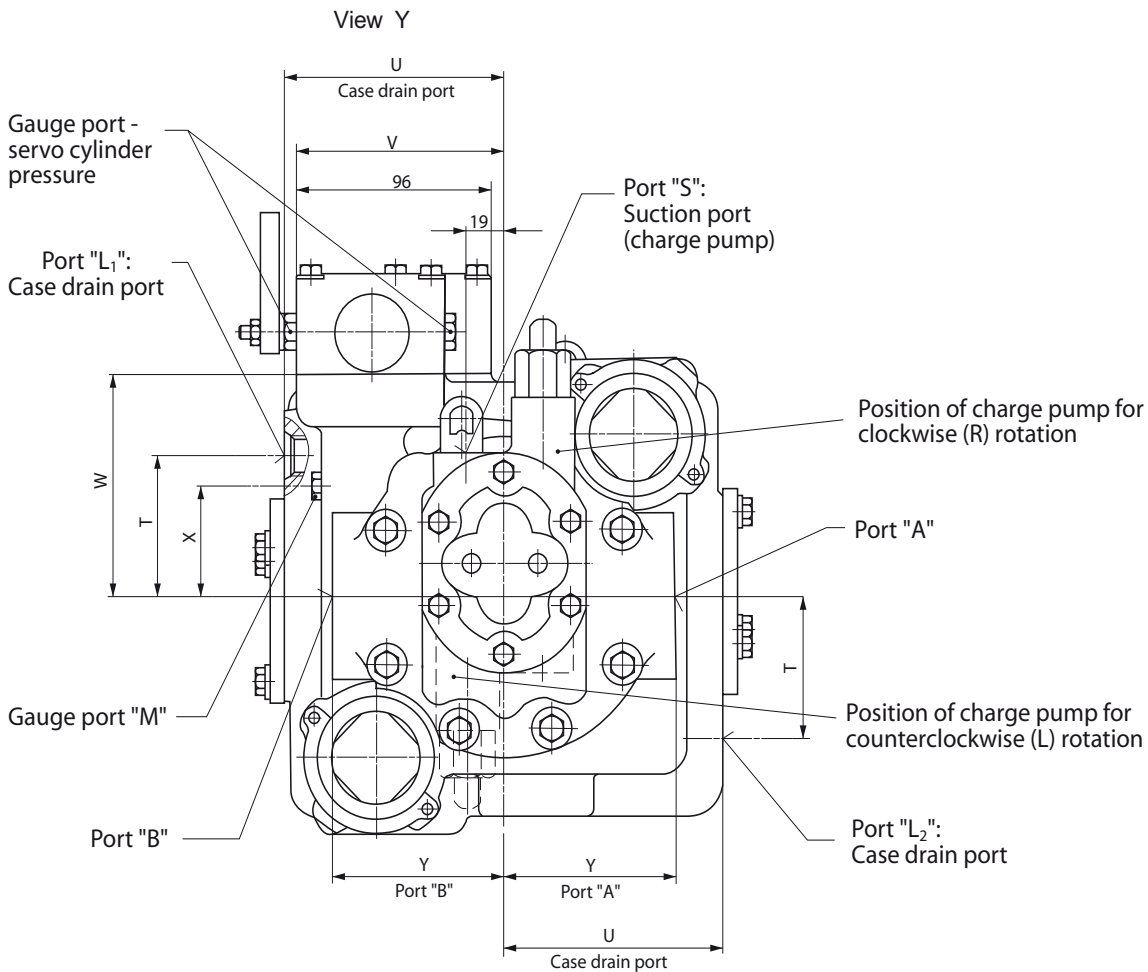

Max. torque for charge pump inlet port (7/8 -14 UNF - 2B) is 22 - 28 Nm [195 - 248 lbf•in].

Frame size	Port A and B	Port L1 and L2	Port S	Port M
20	SAE flange, size 1 SAE split flange boss 1 000 psi 4 threads 7/16-14 UNC-2B 18 deep		7/8-14 UNF-2B SAE straight thread O-ring boss	7/16-20 UNF-2B SAE straight thread O-ring boss
21				
22				
23				

## DRAWINGS

### FRAME SIZE 20, 21, 22 AND 23

View X (for SHPV 20 - 21 only)

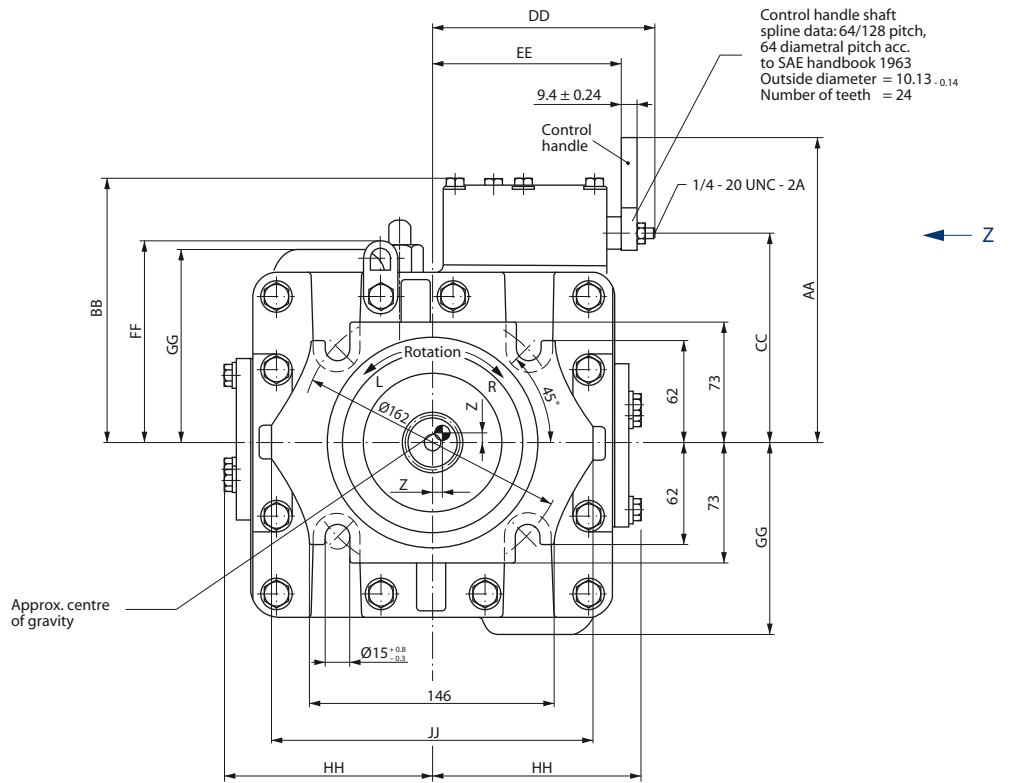

View X (for SHPV 22 only)

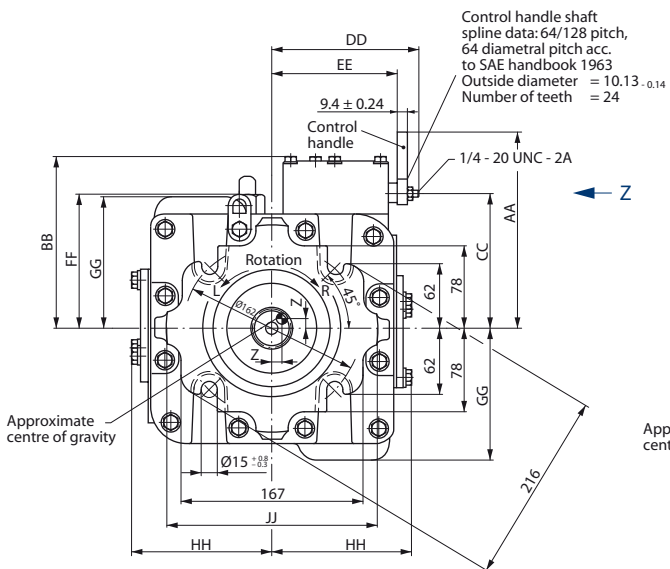

View X (for SHPV 23 only)

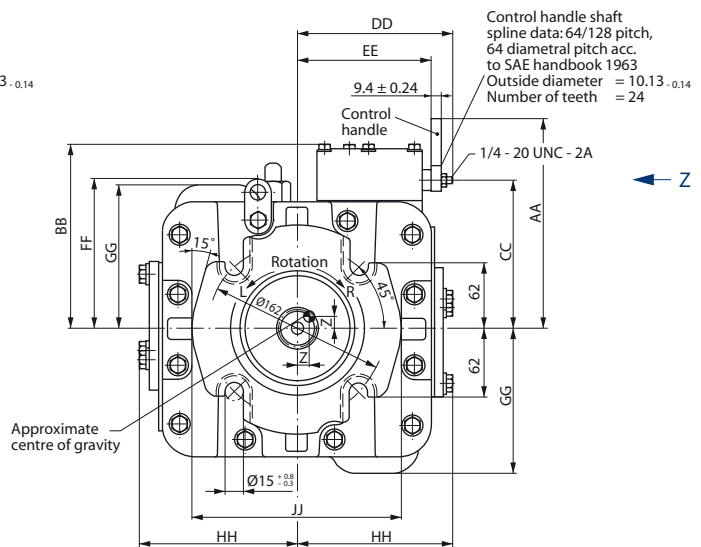



## DRAWINGS

### FRAME SIZE 20, 21, 22 AND 23

Dimensions:

Frame size	B mm [in]	C mm [in]	D mm [in]	E mm [in]	F mm [in]	G mm [in]	H mm [in]	J mm [in]	K mm [in]	L mm [in]	M mm [in]	ØN mm [in]
<b>20</b>	284 [11.181]	263 [10.354]	270 [10.630]	225 [8.858]	162 [6.378]	159 [6.260]	100 [3.937]	94 [3.701]	58 [2.283]	48 [1.890]	16 [0.630]	84 [3.307]
<b>21</b>	301 [11.850]	280 [11.024]	282 [11.102]	246 [9.685]	174 [6.850]	152 [5.984]	107 [4.213]	106 [4.173]	70 [2.756]	48 [1.890]	16 [0.630]	84 [3.307]
<b>22</b>	315 [12.402]	294 [11.575]	305 [12.008]	259 [10.197]	188 [7.402]	146 [5.748]	112 [4.409]	120 [4.724]	84 [3.307]	48 [1.890]	16 [0.630]	84 [3.307]
<b>23</b>	328 [12.913]	307 [12.087]	312 [12.283]	271 [10.669]	195 [7.677]	140 [5.512]	118 [4.646]	129 [5.079]	91 [3.583]	49 [1.929]	17.5 [0.689]	98 [3.858]

Frame size	T mm [in]	U mm [in]	V mm [in]	W mm [in]	X mm [in]	Y mm [in]	Z mm [in]	AA mm [in]	BB mm [in]	CC mm [in]	DD mm [in]	EE mm [in]
<b>20</b>	62 [2.441]	95.7 [3.768]	92 [3.622]	95 [3.740]	51 [2.008]	81 [3.189]	3 [0.118]	174.9 [6.886]	150 [5.906]	115.9 [4.563]	120 [4.724]	100 [3.937]
<b>21</b>	68 [2.677]	108.7 [4.280]	102 [4.016]	108 [4.252]	53.2 [2.094]	85.8 [3.378]	6.35 [0.250]	187.6 [7.386]	162 [6.378]	128.6 [5.063]	131 [5.157]	110 [4.331]
<b>22</b>	71.4 [2.811]	112.7 [4.437]	105 [4.134]	108 [4.252]	60.5 [2.382]	85.8 [3.378]	9.5 [0.374]	187.6 [7.386]	162 [6.378]	128.6 [5.063]	133 [5.236]	113 [4.449]
<b>23</b>	77.7 [3.059]	128.7 [5.067]	115 [4.528]	119 [4.685]	65 [2.559]	95.2 [3.748]	12.7 [0.500]	198.6 [7.819]	173 [6.811]	139.6 [5.496]	144 [5.669]	123 [4.843]

Frame size	FF mm [in]	GG mm [in]	HH mm [in]	JJ mm [in]	A <sup>1</sup> mm [in]		Shaft spline				Bore diameter for shaft coupling mm [in]	
					Charge pump cm <sup>3</sup> [in] <sup>3</sup>		ØO mm [in]	ØP mm [in]	R mm [in]	S mm [in]		
					12 [0.732]	18 [1.098]						
<b>20</b>	117 [4.606]	113 [4.449]	108 [4.252]	190 [7.480]	341 [13.425]	350 [13.780]	34.50 <sub>-0.17</sub> [1.358 <sub>0.0067</sub> ]	33.338 [1.313]	21 [0.827]	16/32	31.75 <sup>+0.062</sup> [1.250 <sup>+0.0024</sup> ]	
<b>21</b>	122 [4.803]	116 [4.567]	124 [4.882]	191 [7.520]	358 [14.094]	367 [14.449]	34.50 <sub>-0.17</sub> [1.358 <sub>0.0067</sub> ]	33.338 [1.313]	21 [0.827]	16/32	31.75 <sup>+0.062</sup> [1.250 <sup>+0.0024</sup> ]	
<b>22</b>	126 [4.961]	123 [4.843]	130 [5.118]	194 [7.638]	372 [14.646]	381 [15.000]	34.50 <sub>-0.17</sub> [1.358 <sub>0.0067</sub> ]	33.338 [1.313]	21 [0.827]	16/32	31.75 <sup>+0.062</sup> [1.250 <sup>+0.0024</sup> ]	
<b>23</b>	140 [5.512]	134 [5.276]	148 [5.827]	194 [7.638]	358 [14.094]	394 [15.512]	37.68 <sub>-0.17</sub> [1.483 <sub>0.0067</sub> ]	36.513 [1.438]	23 [0.906]	16/32	34.95 <sup>+0.062</sup> [1.376 <sup>+0.0024</sup> ]	

<sup>1</sup> Short version available on request. Please contact SMIT Hydraulics service department.

Information contained in this catalogue is accurate as of the publication date and is subject to change without notice. Performance values are typical values. Customers are responsible for selecting products for their applications using normal engineering methods.



# SMIT

hydraulics

**SMIT Hydraulics**

**Via Pietro Giardini, 318  
41100 Modena - ITALY**

[info@smithydraulics.it](mailto:info@smithydraulics.it)  
[www.smithydraulics.it](http://www.smithydraulics.it)

**PHONE**

+39 059 596 77 44  
+39 059 596 77 45

**FAX**

+39 059 596 08 80  
+39 059 596 08 88

**(Domestic market)**

**(International market)**